

TTAC - ALUMINUM CABLE-BUSBAR TERMINAL (STRAIGHT CONNECTION)

TTAC-600-900-2N

Description

Purpose: Cable to busbar termination for CA or CAA aluminum cables.

Characteristics: Mechanical connection. High electrical conductivity. Pad with two or four NEMA standard holes. There are lugs that lock the head of the screws.

Application: Power distribution lines and substations.

Material: Cast aluminum alloy and hot galvanized steel fittings.

Application Tool: Star or open-ended wrench.

Note: Using of the antioxiide compound INTELTROX is recommended.

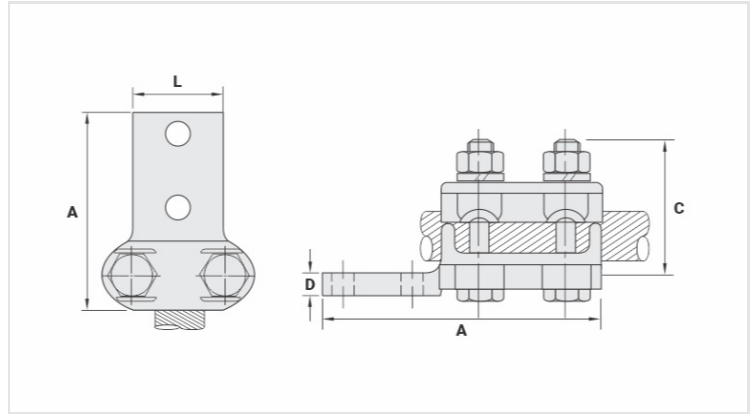

Datasheet

Conductors

CA (AWG/MCM)

600 - 900

CAA (AWG)

477 - 795

Screw

M12

Dimensions

L

52,0

A

174,0

C

70,0

D

12,0

Figura

2

Package

Qtd / Emb

6

Peso Unit. (g)

920,00